

## 15 inch Industrial Panel PC

<b>Model</b>	<b>H1552PA-B64112</b>
--------------	-----------------------

<b>Touchscreen</b>	<b>PCAP or Resistive</b>
--------------------	--------------------------

<b>Version</b>	<b>V 0.1</b>
----------------	--------------

Product Name		15-inch Industrial Panel PC		
Product Model		H1552PA-B64112		
LCD Technical Parameters	Display size	15 inch		
	LCD Brand	BOE Industrial LCD		
	Display Ratio	4: 3		
	Backlight Type	LED		
	Pixel Size	0.297mm x 0.297mm		
	Display Area	Horizontal: 304.128mm	Vertical: 228.096mm	
	Best Resolution	1024×768 @ 60 Hz		
	Response Time	5ms		
	Color	16.2 million		
	Brightness	LCD 300 cd/m <sup>2</sup>		
	Contrast Ratio(Standard Value)	1500:1		
	Viewing Angle (CR > 10)	Horizontal: 170° (85°/85°)	Vertical: 170° (85°/85°)	
	Power Consumption	≤15W		
	Touch Screen Technical Parameters	Touch Screen Type	Capacitive Touch Screen, 4,5 wire resistant	
Cover Glass		Tempered 3mm Ball drop test from 40cm 227g ± 2g		
Transparency		87%		
Hardness		7H		
Interface		USB2.0		
Touch Point		10 or single		
Response Time		≤10 ms		
Touch Method		Finger/ Capacitive pen, With 500g Nylon Wire Labor Gloves (Optional) With Drip Touch and Oil Stain (Optional)		
Single Point Touch Life		≥5000 million times		
Touch Linearity		< 2%		
Single Point Operating System		Windows 8, 10, 11 Linux		
Multi-point Operating System	Windows 8, 10, 11 Linux			
Motherboard Parameters	Processor	Intel®J6412 / 2.00GHz Quad-core Processor 8th Generation I5 optional		
	Memory	DDR4L 4GB, 8G optional		
	Hard Disk	SSD 128GB, 256G optional		

	I/O interface	1 x HDMI out 2 x RJ45 Gigabit Ethernet ports 1 x line-out (green) 1 x MICK (red) 2 x USB 2.0 4 x USB 3.0 1* DC Aviation Plug Power Interface,supports DC 9~36V 1* 2pin Phoenix Terminal,supports DC 9~36V 2* DB9 RS232 serial interface , COM2 supports RS232/485/422 switch, supports 9pin with power function 1* Phoenix Terminal 2*15PIN (4 in 4 out GPIO, with switch signal and COM3~COM6 (RS232/RS485) , 5V VCC and GND) 1* COM3~COM6 RS485/422 setting DIP switch
	WIFI	802.11 b/g/n (optional support)
	Network card	Onboard Realtek 8111E Gigabit Ethernet card
	Operating system	Win8/Win10/Win11/Linux
<b>Technical Parameters</b>	Overall dimensions	359.5mm x 283.1mm x 74.7mm
	Power supply method (optional)	External adapter Adapter Input: 100-240 VAC, 50-60 Hz Adapter Output: 12Vdc/5A
	Power supply voltage	DC 9V~36V
	Maximum power consumption	Less than 40w;
	Heat dissipation	Fanless design , no heat dissipation holes in the whole machine. heat dissipation . front IP65.
	Speaker	3W x 2
	Installation method	VESA and Side buckle screws
	Accessories	Power cord CCCstandard power cord, Chinese style, 1.5meters, black Adapter 60W Installation buckle screws Water proof strip
	Environmental temperature	Working: -10°C~60°C; Storage: -20°C-70°C
	Environmental humidity	Working: 10%-90%; Storage: 10%-90%
	Operating altitude	< 3000 meters
	Warranty	1 year

Approvals                      FCC, CE, RoHS,

产品图片

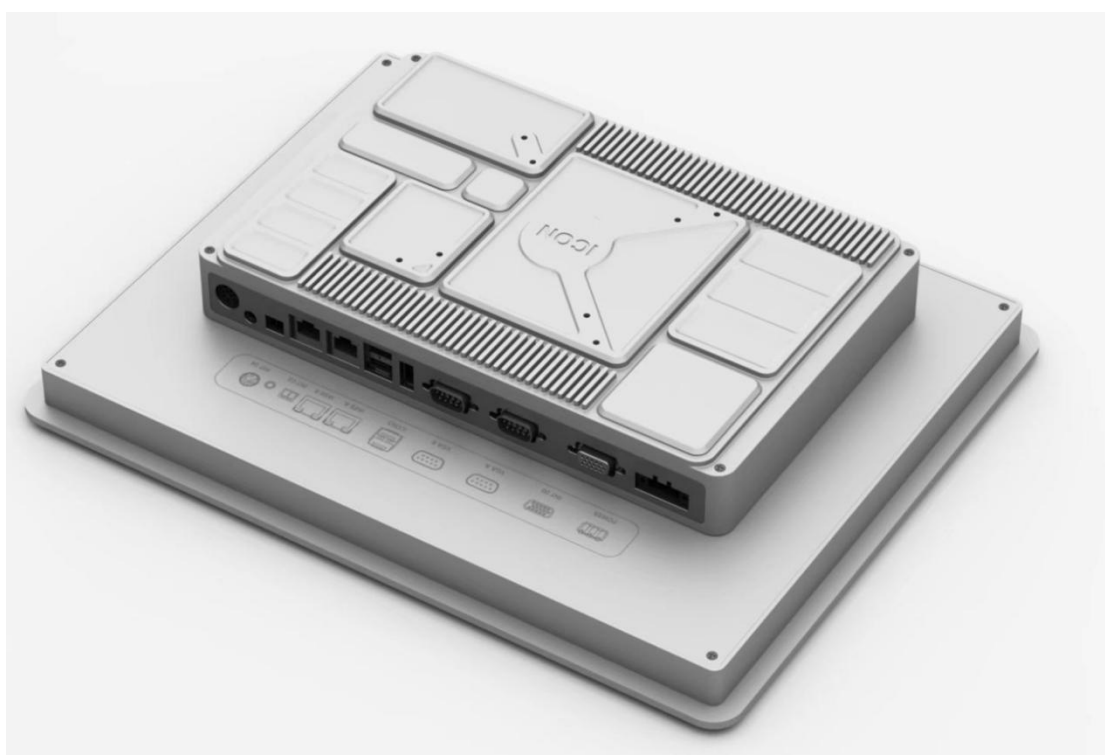

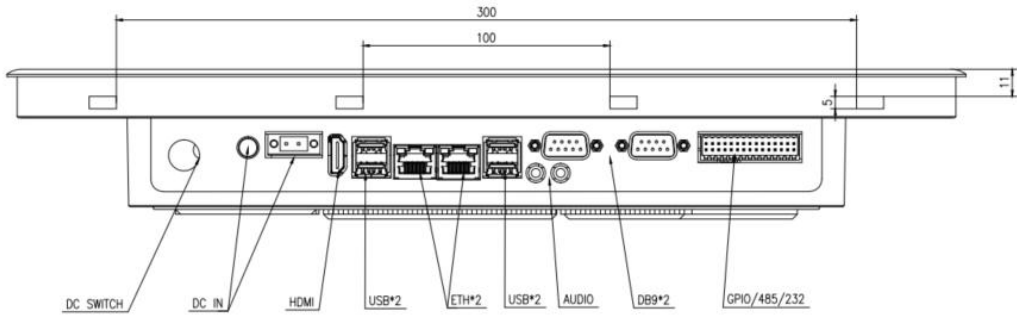
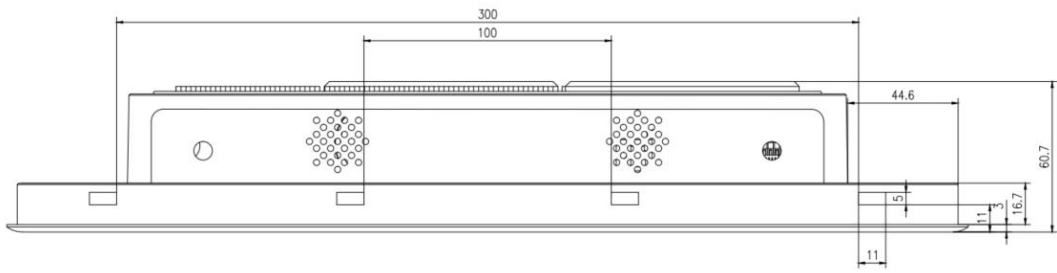

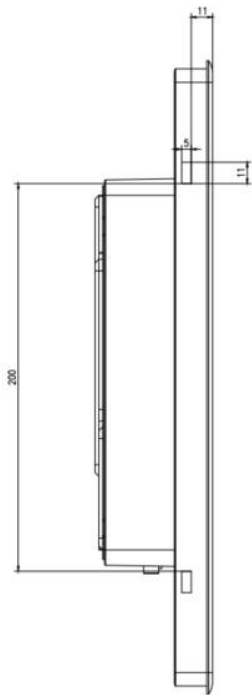
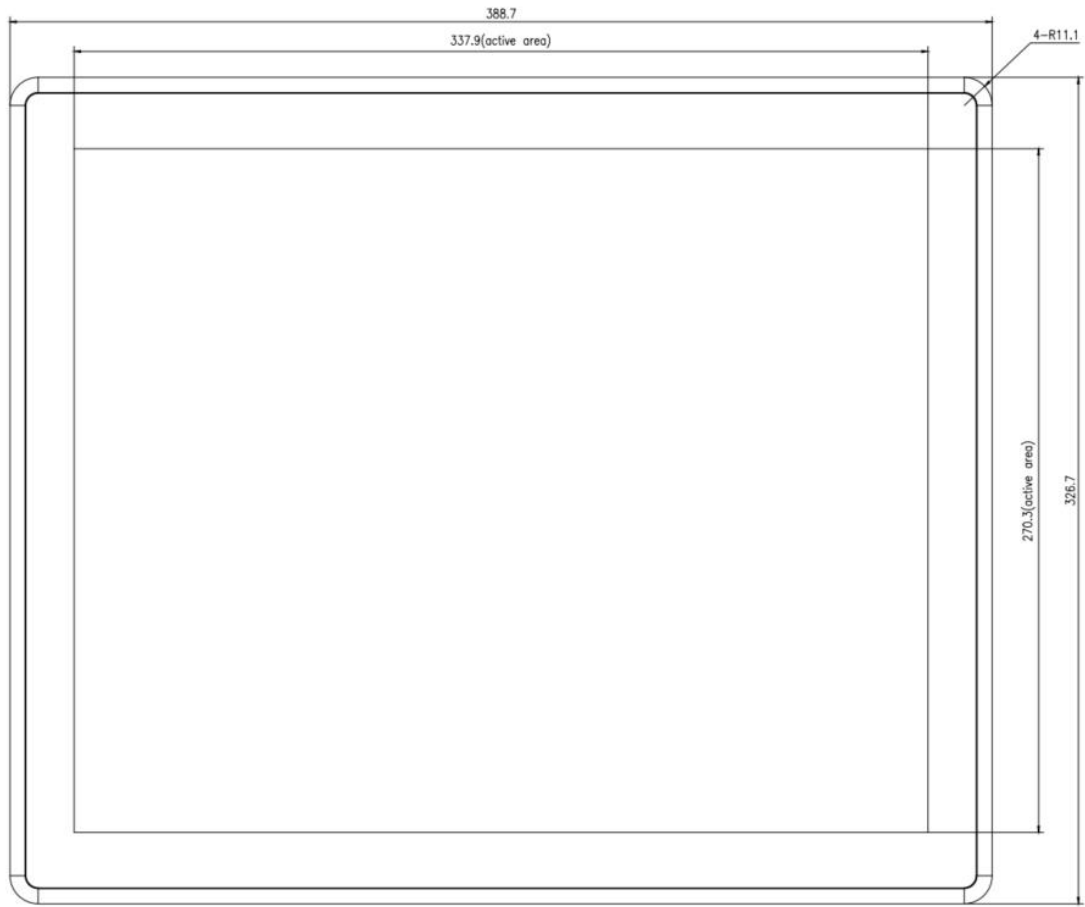

Left

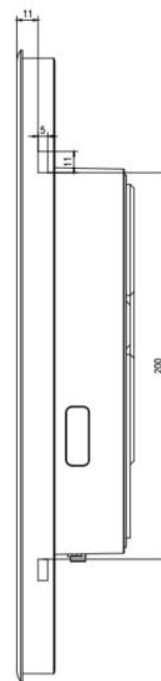

right

